

## SPECIFICATIONS

Design	240 Lit./min(50Hz)
Displacement	300 Lit./min(60Hz)
Speed	2880 r.p.m. (50Hz) 3600 r.p.m. (60Hz)
Normal usage vacuum pressure	Under Torr
Attainable vacuum pressure	Max 50 Torr
Suction port diameter	NPT15A(2) (Option:B.S.P.T)
Motor	B3B5 Motor 3-Phase 220/380V 60Hz 0.75kW 2P
Water Capacity	15°C 3 L/MIN
Weight	30 Kg
Painting	Color - VL951 (Company's standard)
Allowable ambient temp.	-10 - 40°C

-1 Excluding motor and some other parts.

## Curve referred to dry air at 20°C (68°F) 배기량 SUCTION CAPACITY

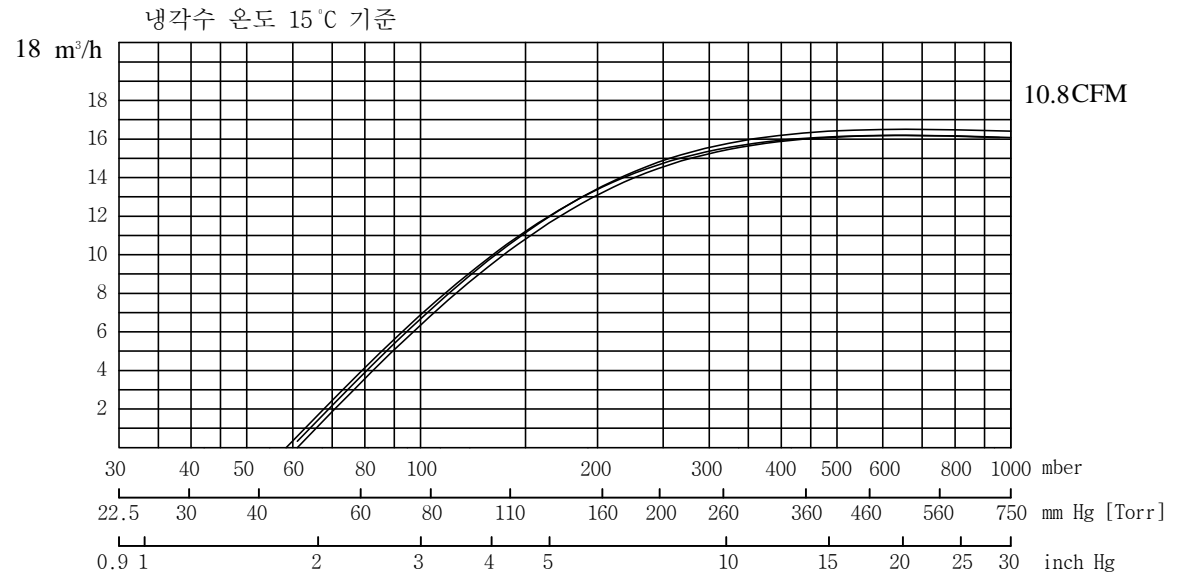

## ACCESSORIES(Option)

- Vacuum Manual Valve
- Vacuum gauge
- Vacuum Check Valve
- Separator Tank

## CONSUMABLE LIST

(Vacuum.ENG GENUINE PARTS)

Designation	Specification	Quantity/set
M/C Seal	∅20	1
Bearing	0000 ZZ (Special Heat - resisting grease)	2
Half Coupling	Direct	
ACC		

DWG DATE	SCALE		TITLE
2009.08.20	N/S		WATER RING V/P
DWG BY	DES BY	CHD BY	APPROVE
			LOCATION
			DWG NO
			JDRP-D2

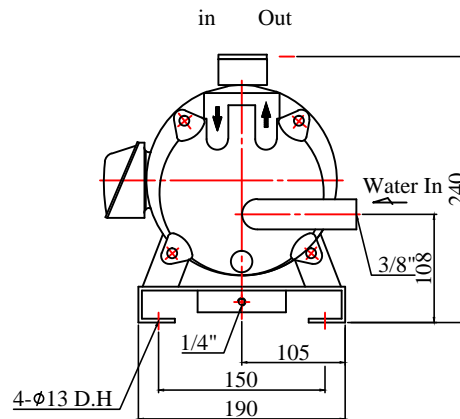
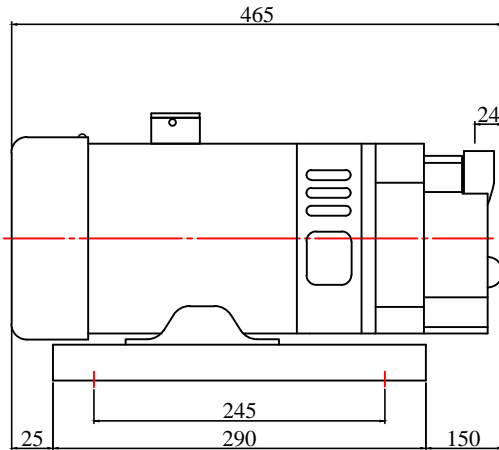

- 품질 개선을 위하여 예고없이 변경 될 수 있음.

- Not binding dimension that can change according to motor make.