

SPECIFICATIONS

Design	2640 Lit./min(50Hz)
Displacement	3300 Lit./min(60Hz)
Speed	1400 r.p.m. (50Hz)
	1750 r.p.m. (60Hz)
Normal usage vacuum pressure	Under Torr
Attainable vacuum pressure	Max 22.5Torr
Suction port diameter	JIS 50A (2) (Option:B.S.P.T)
Motor	B3 Motor () 3-Phase 220/380V 60Hz 8.6kW 4P
Water Capacity	15°C 16 L/MIN
Weight	145 Kg
Painting	Color- VL951 (Company's standard)
Allowable ambient temp.	-10 - 40C

- 1 Excluding motor and some other parts.
- B3B5 MOTOR IEC FANGE

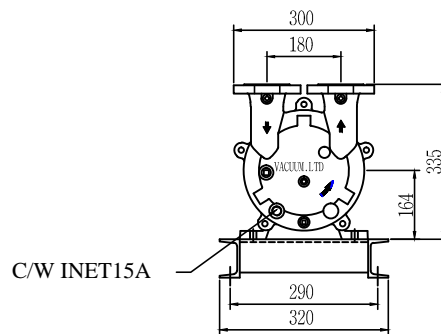
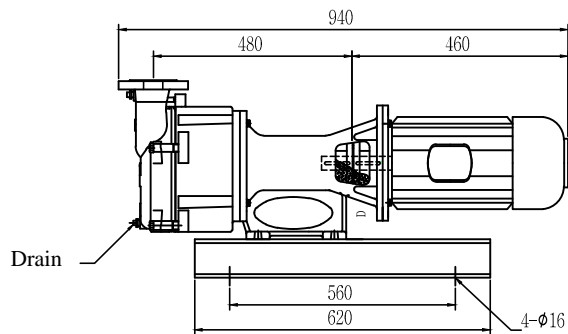
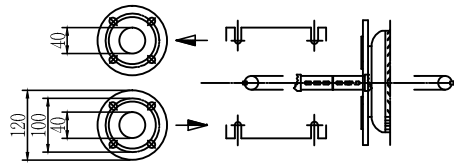

Curve referred to dry air at 20°C (68°F) 배기량 SUCTION CAPACITY

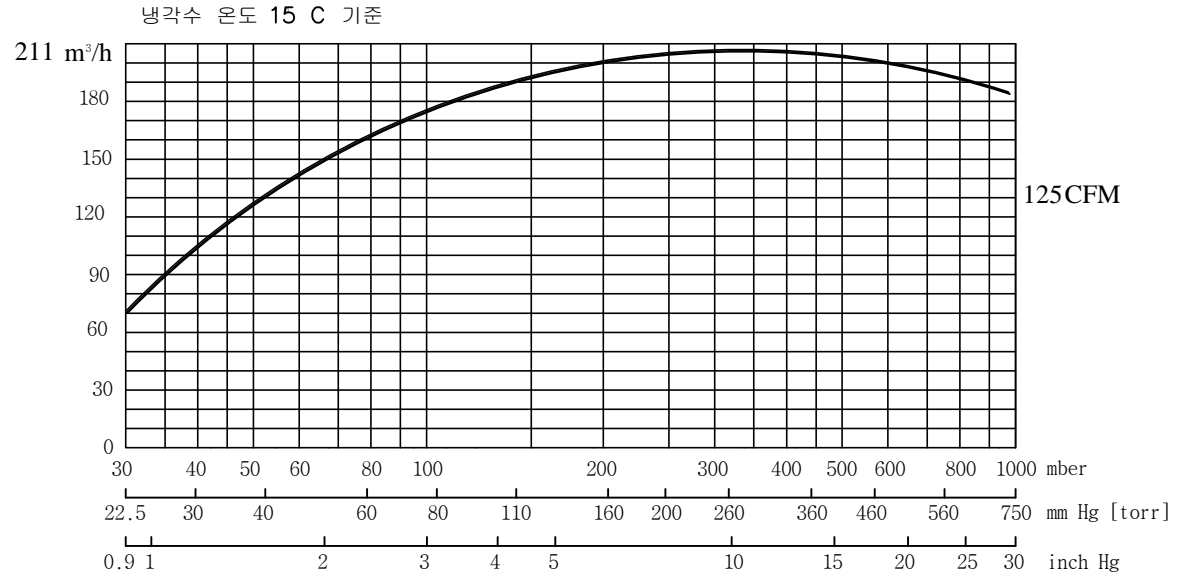

ACCESSORIES(Option)

- Vacuum Manual Valve
- Vacuum gauge
- Vacuum Check Valve
- Separator Tank

CONSUMABLE LIST

(Vacuum.ENG GENUINE PARTS)

Designation	Specification	Quantity/set
M/C Seal	∅ 45	1
Bearing	6307,6206 ZZ (Special Heat - resisting grease)	각 1
Half Coupling	∅ 100	1
Shaft Key	∅ 28 8x4	1

- STS일 경우
- 품질 개선을 위해서 예고없이 변경 될수 있음.
- Not binding dimension that can change to motor make

DWG DATE	SCALE		TITLE	WATER RING V/P
2020.03.15	N/S		CLIENT	
DWGBY	DESNBY	CHDBY	APPROVE	LOCATION
				DWG NO
				JDRP-9MS