

## SPECIFICATIONS

Design	5200 Lit./min(50Hz)
Displacement	6500 Lit./min(60Hz)
Speed	1400 r.p.m. (50Hz)
	1750 r.p.m. (60Hz)
Normal usage vacuum pressure	Under Torr
Attainable vacuum pressure	Max 22.5 Torr
Suction port diameter	JIS 80A (2) (Option:B.S.P.T)
Motor	Vertical Motor Standard 3-Phase 220/380V 60Hz 15kW 4P
Water Capacity	15 °C기준 30 L/MIN
Weight	280 Kg
Painting	Color- VL951 (Company's standard)
Allowable ambient temp.	-10 - 40°C

- 1 Excluding motor and some other parts.
- IEC FANGE MOTOR 부착기준

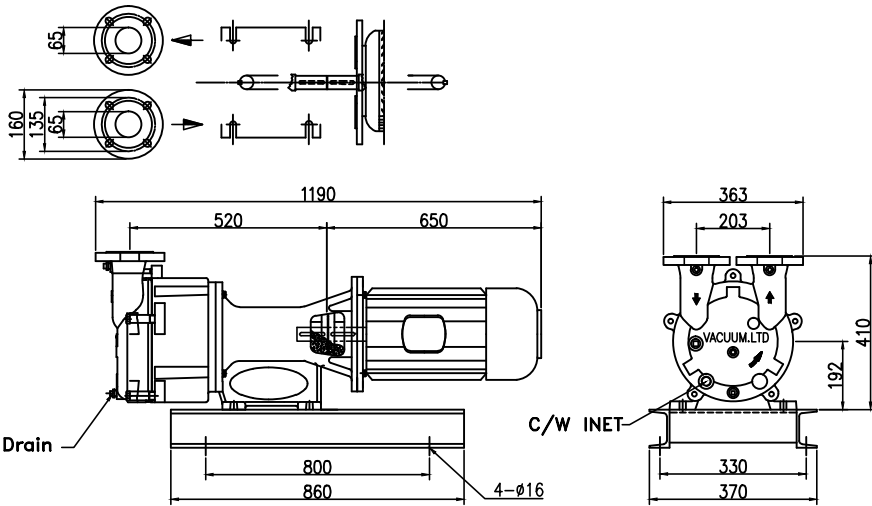

- 품질개선을 위하여 예고없이 변경될수 있음.
- Not binding dimesion that can change according to moter make

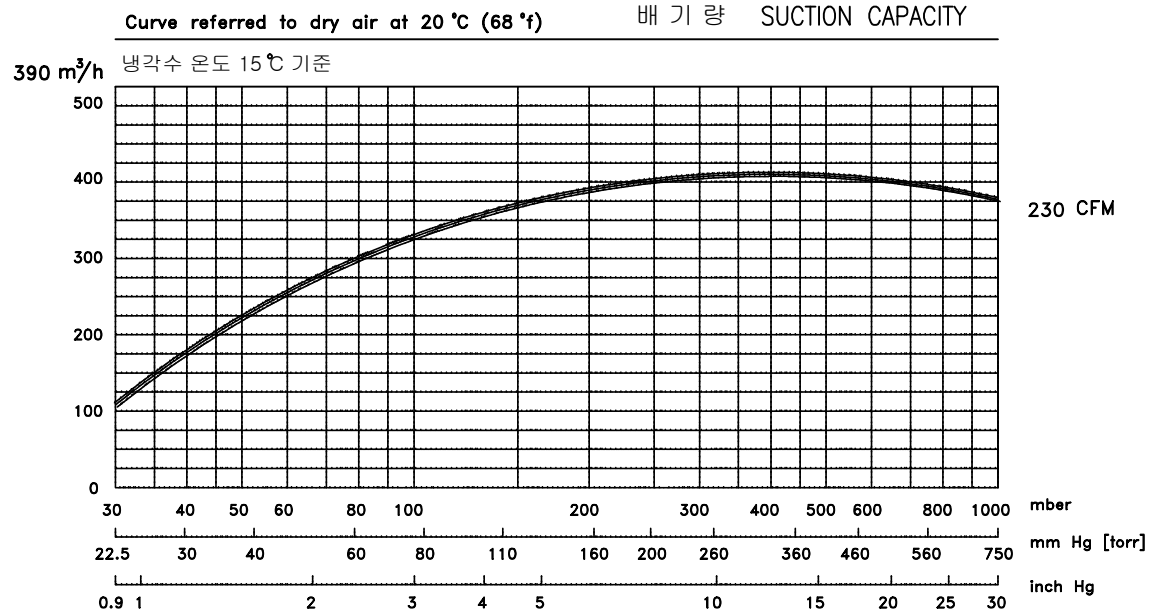

### ACCESSORIES(Option)

- Vacuum Manual Valve
- Vacuum gauge
- Vacuum Check Valve
- Separator Tank

### CONSUMABLE LIST (Vacuum.ENG GENUINE PARTS)

Designation	Specification	Quantity/set
M/C Seal	Bellows Type ø55	1
Bearing	6310,6208 ZZ(Special Heat-resistingrease)	각 1
Half Coupling	ø130	1
Shaft key	ø38 10x4	1

DWG DATE 2000.00.00	SCALE N/S		TITLE WATER RING V/P
DWGBY	DESBNBY		CHDBY
			CLIENT
			LOCATION
			DWG NO JDRP1-13S